

Notes on Safety

◎Please read the instructions & quick setting guide thoroughly before installing or operating the unit.

◎Please do not mount the machine on an unstable surface or bracket.

◎Please prevent liquids or other material from entering the dome housing.

◎When connecting the power source, please follow all electrical safety standards and procedures. Use only the power supply designed for this device. The speed dome's RS-485 and video signal uses TVS technology to protect it from strong electrical surges. This technology prevents damage to the device resulting from impulse signals such as lightning strikes or surges of power. Allow for enough distance between the RS-485 and video signals and high-voltage equipment or cables during the transmission process. Please do not power the unit until all connections are secure and installation is complete.

◎Avoid shooting very bright objects directly into the camera's CCD (such as the sun or light fittings).

◎When the machine is not operating properly, please refer to the instructions for information about how to service or repair

your speed dome.

- ©Please protect the unit against extremes of vibration, pressure or dampness while transporting unit. Damage can occur from improperly packaging the unit while shipping.
- ©The outdoor dome camera system is designed to be installed in outdoor environments only.

INDEX

I . INTRODUCTION.....	1
II. TECHNICAL DATA.....	1
III. SETTINGS.....	2
3.1 XTS-SO10XDN-WP DOME ADDRESS, TRANSMISSION SPEED, PROTOCOL SETTING	3
3.1.1 SPEED DOME CAMERA COMMUNICATION ADDRESS SETTING	4
3.1.2 SPEED DOME CAMERA COMMUNICATION PROTOCOL SETTING.....	4
3.1.3 SPEED DOME CAMERA TRANSMISSION SPEED SETTING (BAUD RATE SETTING).....	5
3.1.4 RS-485 BUS MATCHING RESISTANCE	6
3.2 XTS-SO10XDN-IND DOME ADDRESS, TRANSMISSION SPEED, PROTOCOL SETTING	6
3.2.1 SPEED DOME CAMERA COMMUNICATION ADDRESS SETTING	7
3.2.2 SPEED DOME CAMERA COMMUNICATION PROTOCOL SETTING.....	8
3.2.3 SPEED DOME CAMERA TRANSMISSION SPEED SETTING (BAUD RATE SETTING).....	8
3.2.4 RS-485 BUS MATCHING RESISTANCE	9
IV. BASIC FUNCTION OF DOME CAMERA.....	10
4.1 OBJECTIVE TRACKING	10
4.2 PRESET POSITION SETTING / ADJUSTING *.....	10
4.3 DOME PATTERN TOURS *	10
4.3.1 <i>Preset Position Parameter Setting</i>	10
4.3.2 <i>Pattern Tours Setting</i>	11
4.4 AUTO SCANNING.....	11
4.4.1 <i>Point A to B Scanning</i>	11
4.4.2 <i>360° Scanning *</i>	11
4.5 AUTO-FLIP	11
4.6.1 <i>Focus Change</i>	11
4.6.2 <i>Focus Control</i>	11
4.6.3 <i>Iris Control</i>	12

4.7 MEMORY FUNCTION AS POWER OFF	12
4.8 AUTO-REPOSITION	12
V. CAMERA MENU (OSD MENU) SETTING.....	13
5.1 SYSTEM INFORMATION	13
5.2 SPEED DOME OSD SETTING WITH CONTROL KEYBOARD	14
VI. CAMERA OPTIONAL FUNCTIONS.....	24
6.1 ALARM LINKAGE FUNCTION	24
6.2 PRESENT POSITION CHAR OVERLAP FUNCTION	24
VII. PROTOCOL ORDER.....	24
VIII. ADDRESS-BINARY CODE CHART.....	27
IX. EXCEPTION HANDLING.....	36

* indicates the functions with default protocol, it might not function by using other protocols.

indicates the optional functions, only with certain models

I . Introduction

Congratulations on purchasing our speed dome, an intelligent, high-speed dome with a high-performance DSP camera and sophisticated zoom lens. It is an advanced technological surveillance product combining an all-direction variable speed dome and digital decoder all in one unit. It can aim quickly and scan continuously, making omni-directional and non-blind-spot monitoring into reality. Additionally, it can quickly adapt to changing environments with its 18x optical and 12x digital zoom with precise stepping motors. The advanced stepping motor technologies enable the dome to rotate smoothly, respond sensitively and aim precisely. The speed dome camera has a memory function so when the power cuts off it can auto resume to previous working status. Use our high-performance speed dome “When it Counts.” All of the features make the intelligent high-speed dome camera fit for a wide range of applications such as intelligent building, bank, street of city, airport, station etc..

II . Technical Data

Technical Parameters of the Intelligent High-speed Dome

Model	Outdoor Day/Night Speed Dome	Indoor Speed Dome
Power Supply	AC24V±4V	
Operating temperature	- 40℃~+60℃	0℃~+40℃
Operating moisture	≤95%	
Power consumption	≤20W	
Communication	RS-485 bus	
Communication transmission speed	1200bps / 2400bps / 4800bps / 9600bps	
Horizontal rotation speed	0.1° - 280°/s (1-64 grade shift gears)	
Horizontal rotation range	360°	
Tilt rotation range	90°	
Auto flip	2 grades (Horizontal 180° for 1 st grade, Vertical 90° for 2 nd grade)	
Auto zoom speed control	Control speed auto-adjusted according to zoom length changing	
A-B points scan *	Can set freely	
A-B points scan speed *	1- 64 grade available	
Dwell time at preset position *	1 - 60s available	
Preset Positions *	128 pcs	
Running to preset speed *	1 - 64 grade available	
Cruise Tour *	8 group	
Cruise Points Qty per cruise group *	16 preset positions	
Pattern *	1 pc	
Pattern Memory Time *	88 Seconds	
Privacy Zone *	2	
Fan & Heater #	Temperature auto-controlled	

* indicates the functions with default protocol, it might not function by using other protocols.

indicates the optional functions, only with certain models.

III. Settings

The setting of XTS-SO10XDN-WP and XTS-SO10XDN-IND is partly different, 3.1 corresponds to the setting of VT-SP100W, 3.2 corresponds to the

3.1 XTS-SO10XDN-WP Dome Address, Transmission Speed, Protocol Setting

Before the dome is installed, the communication protocol, baud rate and dome address, should be confirmed. Set the code switch, keeping the setting consistent with the control system. The relative code switch site and connecting wires are diagramed below for reference.

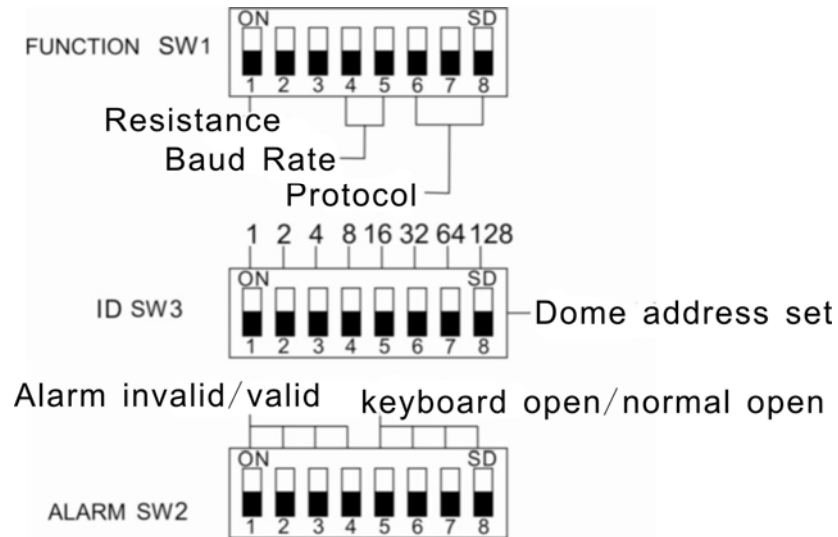

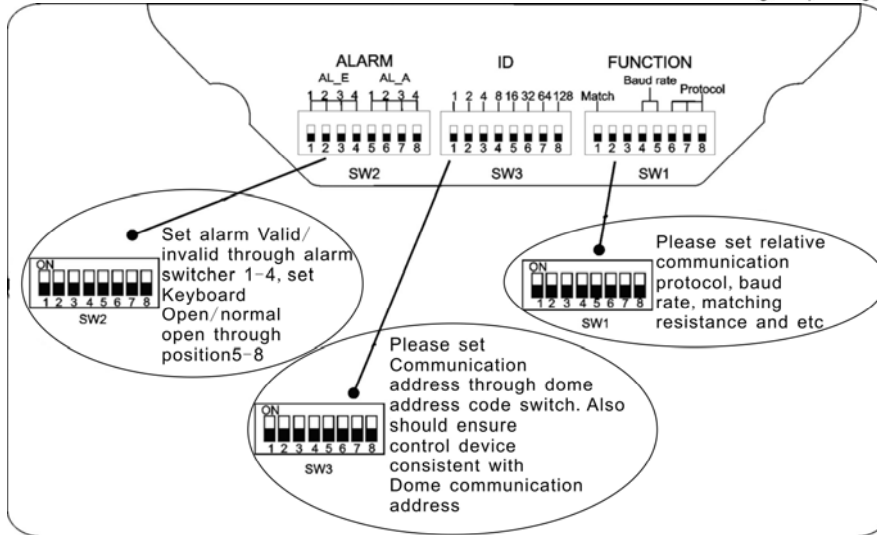



3.1.1 Speed Dome Camera Communication Address Setting

The communication address code for the speed dome should be properly set before use to ensure accurate addressing of the dome at the control center and to control several dome cameras. The address code is made up of SW3 (8 bits) on PCB board. The 8 bit switch uses the 8421 binary coded decimal system. The largest value is 256. 1 means ON status and 0 means OFF status.

3.1.2 Speed Dome Camera Communication Protocol Setting

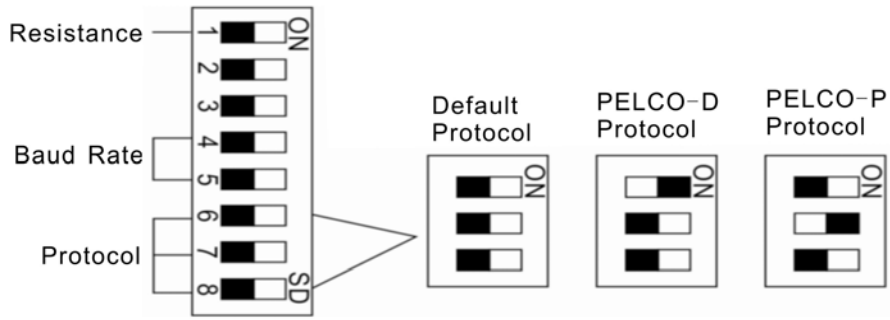
The 1st, 2nd and 3rd bits in SW2 are used to set communication protocol (see following figure)



 After establishing the communication protocol, please restart the unit to save changes.

3.1.3 Speed Dome Camera Transmission Speed Setting (Baud Rate Setting)

The 4th and 5th bits of SW2 on the PCB board are used to set the baud rate (see following figure). The default baud rate setting is 9600 bps.

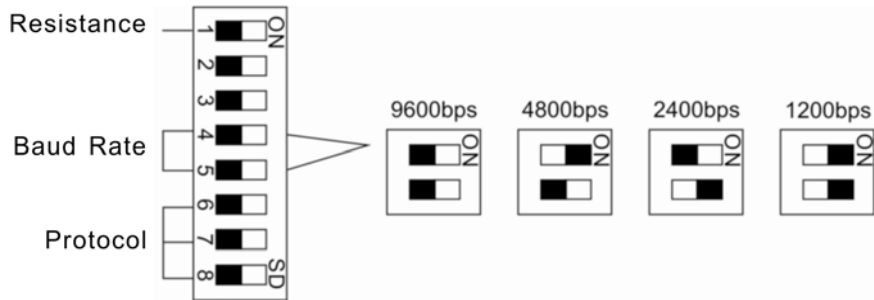

Baud Rate Options: 1200bps 、 2400bps 、 4800bps、 9600bps

Please refer to the controlling device and protocol for baud rate requirement.

 After establishing the transmission speed , please restart the unit to save changes.

3.1.4 RS-485 Bus Matching Resistance

For better centralized control, a matching resistance should be connected in a parallel way at the connecting port where the RS-485 is connected into the device which is the furthest away from the center controller. By doing this, reflection and interference from the RS-485 signal and the like can be cleared up. There is a switcher for controlling of the matching resistance in SW2. And the matching resistance is connected to the RS-485 cable when the “No. 8” switcher is set to “ON” status (see following figure).



When dome is out of control or doesn't work under RS-485 BUS control status, please set switch of matching resistance as ON status so that we can clear up bad phenomenon.



If dome address, baud rate and communication protocol is required to be reset after finish installation, please ensure dome is under power off status.

3.2 XTS-SO10XDN-IND Dome Address, Transmission Speed, Protocol Setting

Before the dome is installed, the communication protocol, baud rate and dome address, should be confirmed. Set the code switch, keeping the setting consistent with the control system. The relative code switch site and connecting wires are diagramed below for reference.

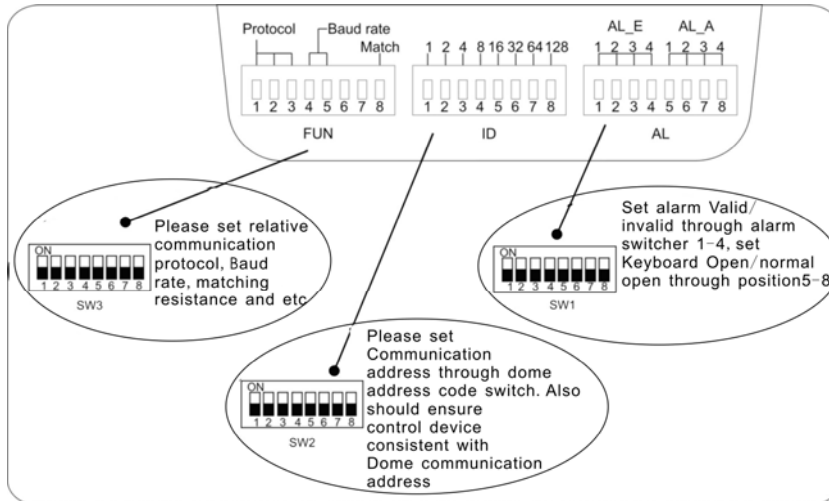
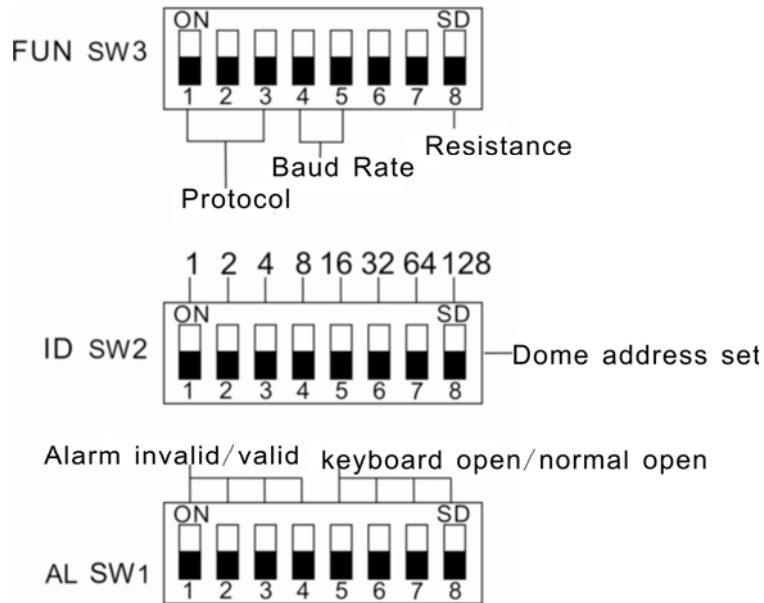

3.2.1 Speed Dome Camera Communication Address

Setting

The communication address code for the speed dome should be properly set before use to ensure accurate addressing of the dome at the control center and to control several dome cameras. The address code is made up of SW3 (8 bits) on PCB board. The 8 bit switch uses the 8421 binary coded decimal system. The largest value is 256. 1 means ON status and 0 means OFF status.

3.2.2 Speed Dome Camera Communication Protocol Setting

The 1st, 2nd and 3rd bits in SW2 are used to set communication protocol (see following figure)

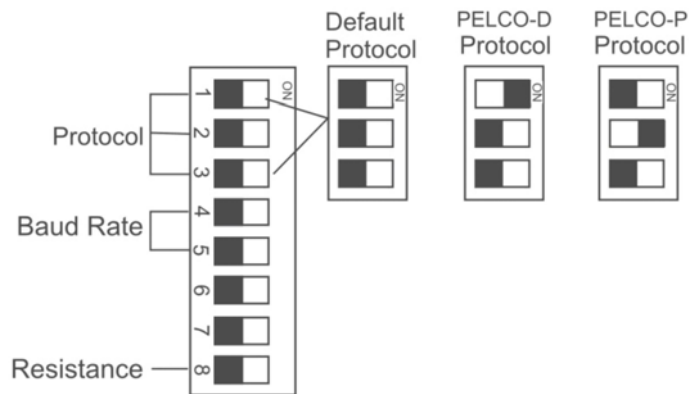

After establishing the communication protocol, please restart the unit to save changes.

3.2.3 Speed Dome Camera Transmission Speed Setting (Baud Rate Setting)

The 4th and 5th bits of SW2 on the PCB board are used to set the baud rate (see following figure). The default baud rate setting is 9600 bps.

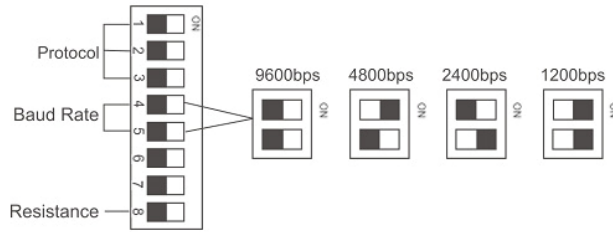



Baud Rate Options: 1200bps 、 2400bps 、 4800bps、 9600bps
 Please refer to the controlling device and protocol for baud rate requirement.

 After establishing the transmission speed , please restart the unit to save changes.

3.2.4 RS-485 Bus Matching Resistance

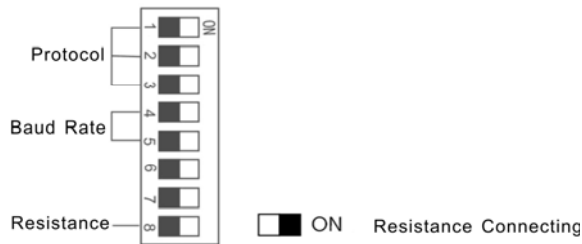
For better centralized control, a matching resistance should be connected in a parallel way at the connecting port where the RS-485 is connected into the device which is the furthest away from the center controller. By doing this, reflection and interference from the RS-485 signal and the like can be cleared up. There is a switcher for controlling of the matching resistance in SW2. And the matching resistance is connected to the RS-485 cable when the “No. 8” switcher is set to “ON” status (see following figure).



 When dome is out of control or doesn't work under RS-485 BUS control status, please set switch of matching resistance as ON status so that we can clear up bad phenomenon.

 **If dome address, baud rate and communication protocol is required to be reset after finish installation, please ensure dome is under power off status.**

IV. Basic Function of Dome Camera

Use the keyboard controller to utilize the complete potential of the speed dome. (The keyboard control protocol is set as the default protocol for the speed dome.)

4.1 Objective Tracking

A user can rotate the camera lens up, down, left and right to view objects through the field of vision using the control keyboard. In addition, a user can adjust focal length to change the angle of view or the size of the objects. When in auto-iris and auto-zoom mode, the camera adjusts automatically to get a clear picture with changing image environments.

4.2 Preset Position Setting / Adjusting *

The Preset function is the dome's default level angle, lean angle and camera focal length in EMS memory. By using this saved parameter, the dome and camera can run to the preset positions when it is required. The operator can save and adjust preset positions by using the control keyboard; the speed dome can support 128 preset positions.

4.3 Dome Pattern Tours *

Before using the control keyboard to setup a speed dome pattern tour, please set the parameters of preset positions first. If not, the speed dome will run according to default setup.

4.3.1 Preset Position Parameter Setting

The speed dome camera has the capacity to set preset positions through the keyboard. It can program the running speed to each preset position from 0.1°/s to 280°/s (1-64grades) and dwelling time from (1-60seconds).



The speed dome can rotate at low speeds and at fast speeds. Its speed can be divided into 64 levels. 1 is the lowest speed and 64 is the fastest speed.

* indicates the functions with default protocol, it might not function by using other protocols.

4.3.2 Pattern Tours Setting

- 4.3.2.1. The Speed dome camera has the capacity to set up to 8 pattern tours each of which can have up to 16 preset positions.
- 4.3.2.2. Add preset positions in the pattern tours.
- 4.3.2.3. Set dwell time (1-60 seconds) and the rotational speed (1-64 grades) of each present positions.
- 4.3.2.4. Start pattern tours: Cruise scanning

4.4 Auto Scanning

4.4.1 Point A to B Scanning

The camera can also run a simple auto point A to B scan. By using the speed dome control keyboard, you can set the parameter of location and running speed at points A and B.

4.4.2 360° Scanning *

The camera can also start an auto cruise scan. This scan will rotate 360° from the desired position. By using the speed dome control keyboard, you can set the running speed. (We suggest you do not use this function for too long time.)



When speed dome camera is under the auto scanning, point A to B scanning or 360° scanning status, you can use the joystick if you want it to stop scanning.

4.5 Auto-Flip

When the speed dome camera is at vertical 90°, it flips automatically.

4.6 Camera-control

4.6.1 Focus Change

User can adjust the distance of focus by keyboard, and to acquire the required image.

4.6.2 Focus Control

The speed dome's default setting is for auto-adjust focusing. Under special conditions, a user can adjust the focus manually to acquire the required image.



The speed dome will not auto -focus the target object under the following conditions:

- a. The object is not in the center of the picture;
- b. Attempting to view images that are far and near at the same time;
- c. Object is strongly lighted object, such as neon lamp, etc.;
- d. Objects behind glass covered with dust;
- e. Objects moving quickly;
- f. Objects within large area and single color such as wall;
- g. Objects that are too dark or faint.

4.6.3 Iris Control

- (1) The speed dome's default setting is for auto-adjust iris. It can make an adjustment quickly through auto detecting the beam change.
- (2) User can adjust iris size manually through control keyboard to get required image brightness.
- (3) User can renew auto iris after moving the joystick or sending additional commands through the controller (Attn: We suggest you use auto iris).



When controlling the iris manually, the dome locks in its current control position and will not reset the auto-iris even if current object changes. You need to move the joystick or send a control order to reset the auto iris.

4.7 Memory Function As Power off

While power off, the speed dome will automatically save the previous operating status into it's memory.

4.8 Auto-reposition

Auto-reposition is for an important viewing point that the speed dome camera should focus automatically when there is no operation after a defined period of time. User can set the auto-reposition location also the duration time (1-60 seconds) to start or stop this function.

V. Camera Menu (OSD Menu) Setting

5.1 System Information

5.1.1 The speed dome will automatically start self-testing once power is on. The following default information of the speed dome will be displayed on the screen of the monitor.

SYSTEM INFORMATION:

1. PROTOCOL: **PELCO** (Indicating the current protocol is PELCO)
2. BAUD RATE: **9600BPS** (Indicating the current baud rate is 9600bps)
3. SPEED DOME ID: **001** (Indicating the current speed dome addressed is "001")VERSION
5.00 w COPYRIGHT RESERVED(XTS VIDEO INC.)

5.1.2 After self-testing, 1 group of information will be displayed on the monitor screen as illustrated in diagram 1 as below:

Current azimuth-elevation indication : vertical 71° ; horizontal 126° .

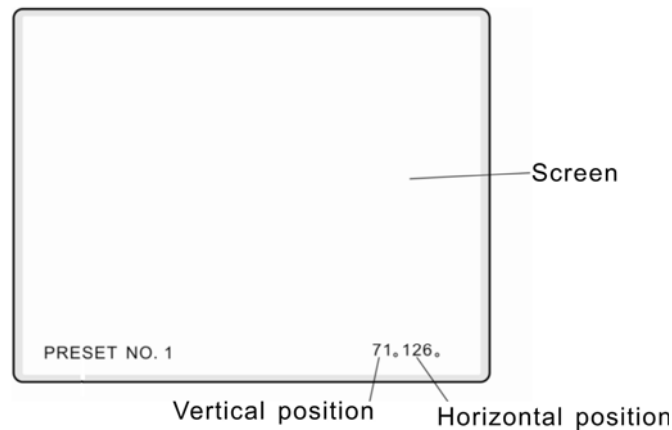



Diagram 1

 Here we suppose it 0° when camera in speed dome heads downward to the floor vertically. The horizontal position is get with the physic position of the camera in speed dome as its reference.
It is different whether time & date are shown or not referring to different speed domes.

5.2 Speed Dome OSD Setting with Control Keyboard

5.2.1 Enter OSD Menu With Default Protocol

5.2.1.1 Select the speed dome address on the keyboard and then press "CAM" key.



Press the "FUN" key once in the main menu of keyboard display (To press the "EXIT" key back to main menu if necessary) to have the following screen:

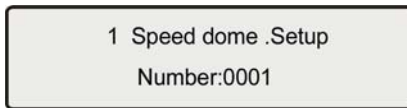

Press "CLR" to reset and then input new address from 1 to 1024, and to press "Enter" for confirmation

5.2.1.2 Then press "FUN" key 4 times and you can see the content displayed below:

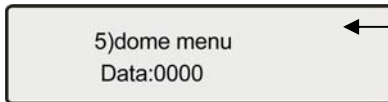

Press "CLR" for erasing and then input new address from 1 to 1024, and to press "Enter" for confirmation

After that, press "Enter" key to enter OSD setting.

5.2.1.3 With the use of PELCO-D、PELCO-P protocols, entering the OSD menu and parameters setting are achieved by selecting the No. 95 preset point.

indicates the optional functions, only with certain models.

5.2.2 The Keys Function

5.2.2.1 Only 4 keys are used for "UP" (the "SEQ" key), "DOWN" (the "MON" key), "LEFT" (the "Area" key) and "RIGHT" (the "CAM" key) for

OSD setting and their functions are listed below respectively:

“UP” (the “SEQ” key): To the previous menu.

“DOWN” (the “MON” key): To the next menu.

“LEFT” (the “Area” key): To reduce such number by “1” at each hit.

“RIGHT” (the “CAM” key): It is a triple-function key playing different roles in different occasions. First, it is a “confirm” key to save current setting. Second, it is a switching key, for example, switching between “ON” and “OFF”. Third, it increases in number by “1” at each hit.

The four keys “SEQ”, “MON”, “Area” and “CAM” on the down-right of the keyboards stand for “UP”, “DOWN”, “LEFT” and “RIGHT” respectively as illustrated in diagram 2 below:

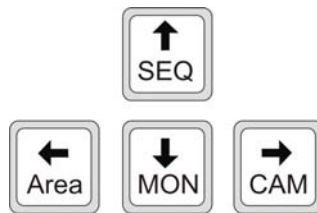

Diagram 2 The Four Keys On Keyboard

5.2.2.2 When the product protocols are PELCO-D、PELCO-P, Entering OSD menu was achieved by setting the No.95 preset point. In OSD menu, The command(up,down,right,left) to control the dome was explained to the operation of menu.

Function	How To Achieve
OSD MENU ENTRY	SET THE PRESET POINT 95
UP	UP
DOWN	DOWN
LEFT	LEFT
RIGHT	RIGHT

After pressing IRIS CLOSE, The command to the dome that keyboard or DVR made was not to control the OSD menu, but the operation of the dome, Press IRIS CLOSE again, the command was retrieved to the operation of the OSD menu.

5.2.3 When the OSD menu display.

">>"it means a new entry to sub-menu with single hit of the key to confirm. "<<" means a new entry from sub-menu to previous menu with single hit of the key to confirm.

"→" and "↑" stand for cursors, all operation works in the columns marked /pointed by cursors.

N/A means this function is not supported.

When saving certain setting to the EEPROM, there is a prompt like "saving..."

Do not give any other input until "OK!" pop up.

In the demonstration below, "X" stands for the numbers or their replacements, i.e., 0~9.

User can only amend such menu which is underlined.

Menu showed in red means different function in different condition.

5.2.4 Menu Demonstration.

5.2.4.1 The primary image at the entry of the menu can be witnessed as follows:

1. PASSWORD: 0000 (You are expected to input your password)
2. EXIT << (Exit OSD menu)

You are expected to input a 4-number password for your entry into the main menu.



- (1) The default passwords of speed dome are 0001, user can set new passwords in relevant menu.

- (2) The universal/general passwords are 2148, it will help when the set passwords forgot.

Please find the structure of the OSD menu in diagram 4 as follows:

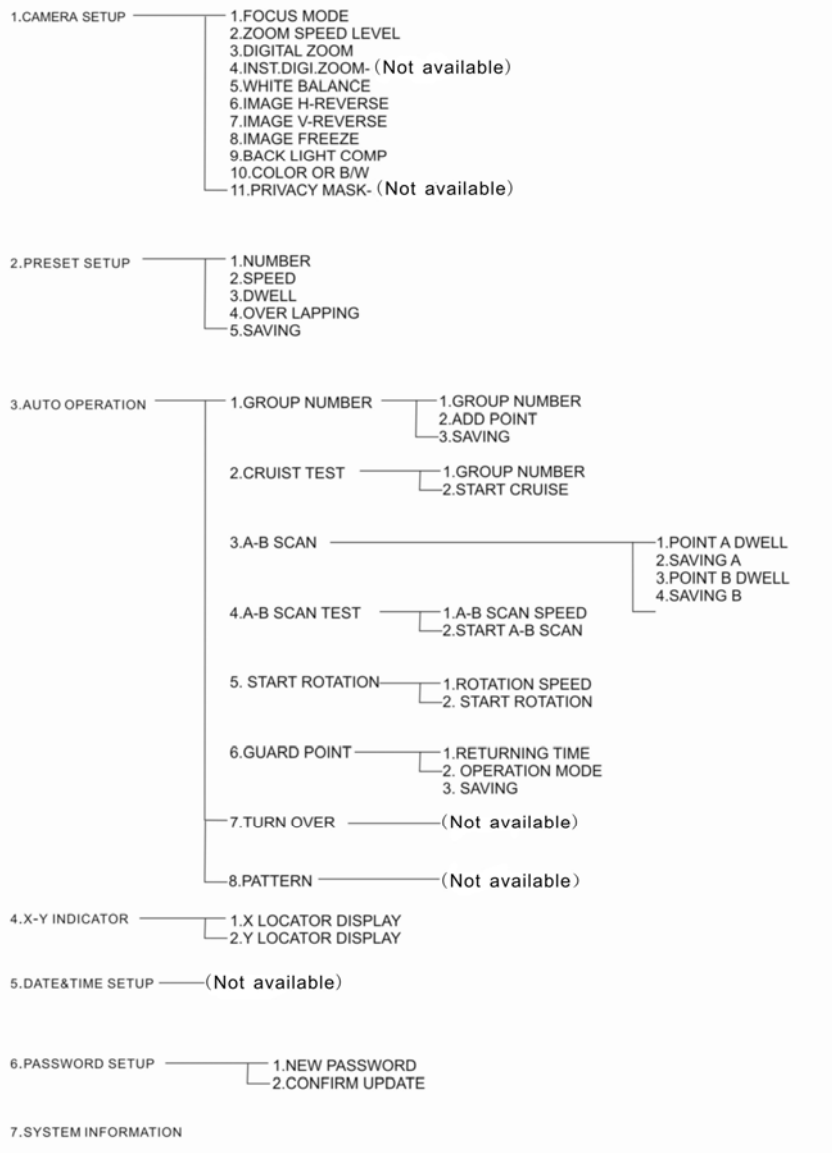

Diagram 3 structure of OSD menu

5.2.4.2 The Main Menu

- 1. CAMERA SETUP >> (Sub-menu for camera function setting).
- 2. PRESET POINT >> (Sub-menu for preset point setting).
- 3. AUTO OPERATION >> (Sub-menu for automatic movements)

setting).

4. X-Y INDICATOR >> (Sub-menu for indicator on horizontal and vertical position of the speed dome/ X-Y INDICATOR display).
5. DATE&TIME SETUP >> (Sub-menu for date and time setting).
6. PASSWORD SETUP >> (Sub-menu for password setting).
7. SYSTEM INFORMATION (Sub-menu for system information display).
8. EXIT MENU << (Exit OSD menu).

5.2.4.3 Sub-menu For Camera Function Setting

1. FOCUS MODE: **AUTO** for FOCUS mode, AUTO and MANUAL alternative.
2. ZOOM SPEED LEVEL: **HIGH** for zoom speed, HIGH and NORMAL alternative
3. DIGITAL ZOOM: **OFF** for zoom on-off, ON and OFF alternative
4. INST.DIGI.ZOOM: N/A **Not available now**
5. WHITE BALANCE: **AUTO** , AUTO and MANUAL alternative. *
6. IMAGE H-REVERSE: **OFF** (Reversion between up and down), ON and OFF alternative.
7. IMAGE V-REVERSE: **OFF** (Reversion between right and left), ON and OFF alternative.
8. IMAGE FREEZE: **OFF** ., ON and OFF alternative.
9. BACK LIGHT: **OFF** , ON and OFF alternative.

10. COLOR OR B/W: **COLOR** , (colorful image will turn to black-and-white in dark condition) Color and B/W alternative.
11. PRIVACY MASK : N/A **Not available now**
12. EXIT SUBMENU <<



Not all cameras are compatible with such functions. If it does not support such function, a “?” mark will appear behind the function.

5.2.4.4 Setting On Preset Points

Enter “2. PRESET POINT >>” in the main menu. In this menu you may not only check data / parameters of the current preset point but also adjust the set data / parameters of the

preset points or even establish a new preset point.

1. NUMBER: XXX (USED)

To select (input) a number for preset point (numbers from 1 to 128 available). If the number for the point used there will be display of "USED" and the speed dome will turn to the preset point automatically to ease your confirmation on position of the point.

Column 2, 3, 4 indicate the relevant information on the preset point, involving speed when the speed dome moves from other points to the preset point; dwelling time at the preset point and the overlapped characters on the preset point display or not etc.. If the preset point has not yet been set, there will be display of "NOT USED".

2. SPEED: XX (1--64) This menu is for adjusting the speed when the speed dome moves from other points to the preset point. "1" stands for the lowest speed while "64" for the highest speed.

3. DWELL: XX (1--60) This menu is for adjusting the dwelling time ("second" as the unit).

4. OVER LAPPING: OFF This menu is for adjusting and displaying the overlapped characters ("ON" for display while "OFF" for not display).

5. SAVING: . . . All the adjustments will be fixed and saved in the chip of speed dome after your press for "confirmation". The saved data won't be lost even in power-off status. (Please be informed that before saving, speed dome should be turned to a proper position and set a proper zooming ratio with the joystick on the keyboard.

6. EXIT SUBMENU <<

5.2.4.5 Menu On Automatic Functions Setting

Enter "3. AUTO OPERATION >>" in the main menu:

1. PRESET CRUISE >> (For the submenu of cruise groups setting).

2. CRUISE TEST >> (For cruise groups testing).

3. A—B SCAN >> (For two points scanning setting).
4. A—B SCAN TEST >> (For two points scanning testing).
5. START ROTATION >> (For the submenu of starting 360° rotation scanning).
6. GUARD POINT >> (For the submenu of auto-reposition setting).
7. TURN OVER >> (For 180° Auto Flip setting) (Not available now) .
8. PATTERN >> (For the submenu of pattern scanning setting).
9. EXIT SUBMENU << (For exiting this submenu and entry into its father menu).

5.2.4.6 Menu On Cruise Group Setting

Enter the “1. PRESET CRUISE >>” menu. For one speed dome, 8 cruise groups (each group includes 16 points with one preset point) available. Speed dome cruises as programmed/set. (Consult 5.2. 4.10 in this manual for setting on preset points).

1. GROUP NUMBER: X Choose serial number for each group (numbers from 1 to 8 available). Completion of setting on the 16 preset points in each group or not will be displayed at finish of group serial number choosing / input. The three numbers “XXX” stands for number of preset point. Provided there is not number displayed , it means preset points not yet been set. For example, “(02)005” means that the second point in the cruise group is numbered as “5” while “(02)” indicates that the second preset point in the cruise group has not yet been set.

2. ADD POINT:

(01)XXX (02)XXX (03)XXX (04)XXX
 (05)XXX (06)XXX (07)XXX (08)XXX
 (09)XXX (10)XXX (11)XXX (12)XXX
 (13)XXX (14)XXX (15)XXX (16)XXX

“XXX” stands for each point amendable in each cruise group.

You can position the cursor in ahead of the serial number of the points to be reset and then start to amend the number. (just like using PC). If the numbers for points in a group are displayed as blank, it means that preset point not yet been set.

3. SAVING.... All of the setting or amendment can not be saved until you click this function panel or nothing saved.

4. EXIT SUBMENU <<

5.2.4.7 Menu on Cruise Testing

1. GROUP NO.: X Choose serial number for each group (No. from 1 to 8 available)

2. START CRUISE: Start to test.

3. EXIT MENU. <<

5.2.4.8 Menu On A — B Scanning

1. POINT "A" DWELL : XX stands for dwelling time amendable (numbers from 0 to 60 seconds available).

2. SAVING.... Setting on point "A". To have speed dome turn to a proper position and have the wanted zooming ratio set with the joystick, then click the "CAM" key in this column/menu to finish setting position、 zooming ratio and dwell time of point "A".

3. POINT "B" DWELL : XX stands for dwelling time amendable (numbers from 0 to 60 seconds available).

4. SAVING Setting on point "B". To have speed dome turn to a proper position and have the wanted zooming ratio set with the joystick, then click the "CAM" key in this column/menu to finish setting position、 zooming ratio and dwell time of point "B".

5. EXIT SUBMENU <<

5.2.4.9 A — B Scanning Test

1. A — B SCAN SPEED: XX Set the speed for A—B scanning (number from 1 to 64 available).

2. START A — B SCAN

3. EXIT SUBMENU <<

5.2.4.10 360° Scanning Test

1. ROTATION SPEED: XX Set the speed for 360° rotation scanning (number from 1 to 64 available).
2. START ROTATION
3. EXIT SUBMENU <<

5.2.4.11 Menu On Auto-reposition Setting

1. RETURNING TIME: XXX Set time for speed dome to return the guard point from any point.
2. OPERATION MODE: ON Switch for Guard Point function "ON" and "OFF" available.
3. SAVING.... To save position, zooming ratio, and returning time etc.. You are expected to adjust and get the ideal position, zooming ratio etc. before saving.
4. EXIT SUBMENU <<

5.2.4.12 Menu On Display Of Speed Dome Position

"ON" for display of horizontal and vertical position of speed dome.

1. X LOCATOR DISPLAY: ON "ON" for display while "OFF" for conceal.
2. Y LOCATOR DISPLAY: ON "ON" for display while "OFF" for conceal.
3. EXIT SUBMENU <<

5.2.4.13 Menu On Display Of Date And Time (This function might be set into some special dome cameras).

1. DATE DISPLAY: ON "ON" for displaying date on down-right of screen while "OFF" for conceal.
2. TIME DISPLAY: ON "ON" for displaying time on down-right of screen while "OFF" for conceal.
3. DATE PRESET >>
4. TIME PRESET >>
5. EXIT SUBMENU <<

5.2.4.14 Menu On Date Setting (This function might be set into some special dome cameras).

It is for display and amendment of current date.

1. YEAR : **XX** For year setting and amendment.
2. MONTH: **XX** For month setting and amendment.
3. DAY: **XX** For day setting and amendment.
4. SAVING.... Amendment won't be saved until click this "SAVING" panel.
5. EXIT SUBMENU <<

5.2.4.15 Menu On Time Setting (This function might be set into some special dome cameras).

It is for display and amendment of current time (24 hours/day format).

1. HOUR : **XX** For hour setting and amendment.
2. MINUTE: **XX** For minute setting and amendment.
3. SECOND: **XX** For second setting and amendment.
4. SAVING.... Amendment won't be saved until click this "SAVING" panel.
5. EXIT SUBMENU <<

5.2.4.16 Menu On Password

Password consists of 4 numbers, which is amendable.

1. NEW PASSWORD: **XXXX** Display the former password, amendable. (Default password: 0001)
2. CONFIRM UPDATE For amended password saving. Amendment fails without click this panel.

3.EXIT SUBMENU <<

5.2.4.17 System Data Display

Click "7. SYSTEM INFORMATION" in the main menu to have the basic information about speed dome displayed such as:

SYSTEM INFORMATION:

1. PROTOCOL: PELCO (Current protocol as "PELCO")
 2. BAUD RATE: **9600BPS** (Current baud rate as "9600bps")
 3. SPEED DOME ID: **001** (Current speed dome address as"001")
- VERSION 5.00COPYRIGHT RESERVED(XTS VIDEO INC)

VI. Camera Optional Functions

6.1 Alarm Linkage Function

Speed dome camera supports a 4 alarm input. Every alarm input end matches a preset position No.: 29, 30, 31, 32.

When speed dome camera detects an alarm input, the camera will automatically turn to the preset position that has been set. When detecting several alarm inputs, the camera will automatically turn to the corresponding preset positions that have been set. Press down Shift+CLR key to clear alarm status under the default protocol. Adjust preset position No. 60 to clear alarm status under other protocols. Then the speed dome camera will come back to the previous status.

6.2 Present Position Char Overlap Function

Through RS-232/RS-485 adapter, speed dome camera can transfer the PC different 232 signal to RS-485 signal which the speed dome can recognize and can be communicated by the attached software. This enables the speed dome display multi-language and images in every preset position. More detail operation please refers to speed dome control software and operation manual.



The software characters overlap does not relate with protocol choosing, but baud rate must be fit with its address.

VII. Protocol Order

For it is compatible with Pelco keyboard order and control order that used before, We have made a change to the software of the dome, add some special functions for example: the control of subsidiary switch, 180 degree reverse and so on, We also made a change to functions setting. SO if using Pelco-D, Pelco-p protocols ,Some detailed functions are shown on the following table.

Chart 1 Camera Functions by Adjusting Preset Position

Preset Position Code	Function
33	180° reversal Viz. flip
34	Return 0° Viz. home
51	Start Point A to B scanning (low-speed)
52	Start Point A to B scanning (mid-speed)
53	Start Point A to B scanning (high-speed)
54	Start No.1 cruise
55	Into Camera OSD Menu
56	Cursor (up)
57	Cursor (down)
58	Cursor(left)
59	Cursor(Right)
60	Clear alarm status
63	Start 360° Scanning(low-speed)
64	Start 360° Scanning(mid-speed)
65	Start 360° Scanning(high-speed)
96	Stop scan
97	Begin random scan
98	Start 360° Scanning(mid-speed)
99	Begin A-B Scan(Mid-speed)

Chart 2 Camera Functions by Loading Preset Position

Preset Position Code	Function
51	Set Point A
52	Set Point B
53	Set Auto-reposition
54	Auto-reposition Open
55	Auto-reposition Close
61	Run Pattern
62	Stop Pattern
92	Set Left Limit Stop(Point A)
93	Set Right Limit Stop(Point B)
95	Enter Menu Mode

If another control device is used to control the speed dome camera, Some of the special functions of Intelligent high speed dome can't be realized because of protocol limitation.

When another control device is used to control the speed dome camera, you will need to set the protocol, address and baud rate correctly. When you set the address, please set the speed dome to an address different from the control device. For example: DVR address is 1, dome camera address should be set as 2 for normal control.

VIII. Address-Binary Code Chart

Binary System Code	Default Protocol	PELCO-D	PELCO-P	SAMSUNG	KALATEL
00000000	1	1	1	0	0
00000001	2	2	2	1	1
00000010	3	3	3	2	2
00000011	4	4	4	3	3
00000100	5	5	5	4	4
00000101	6	6	6	5	5
00000110	7	7	7	6	6
00000111	8	8	8	7	7
00001000	9	9	9	8	8
00001001	10	10	10	9	9
00001010	11	11	11	10	10
00001011	12	12	12	11	11
00001100	13	13	13	12	12
00001101	14	14	14	13	13
00001110	15	15	15	14	14
00001111	16	16	16	15	15
00010000	17	17	17	16	16
00010001	18	18	18	17	17
00010010	19	19	19	18	18
00010011	20	20	20	19	19
00010100	21	21	21	20	20
00010101	22	22	22	21	21
00010110	23	23	23	22	22
00010111	24	24	24	23	23
00011000	25	25	25	24	24
00011001	26	26	26	25	25
00011010	27	27	27	26	26
00011011	28	28	28	27	27

Binary System Code	Default Protocol	PELCO-D	PELCO-P	SAMSUNG	KALATEL
00011100	29	29	29	28	28
00011101	30	30	30	29	29
00011110	31	31	31	30	30
00011111	32	32	32	31	31
00100000	33	33	33	32	32
00100001	34	34	34	33	33
00100010	35	35	35	34	34
00100011	36	36	36	35	35
00100100	37	37	37	36	36
00100101	38	38	38	37	37
00100110	39	39	39	38	38
00100111	40	40	40	39	39
00101000	41	41	41	40	40
00101001	42	42	42	41	41
00101010	43	43	43	42	42
00101011	44	44	44	43	43
00101100	45	45	45	44	44
00101101	46	46	46	45	45
00101110	47	47	47	46	46
00101111	48	48	48	47	47
00110000	49	49	49	48	48
00110001	50	50	50	49	49
00110010	51	51	51	50	50
00110011	52	52	52	51	51
00110100	53	53	53	52	52
00110101	54	54	54	53	53
00110110	55	55	55	54	54
00110111	56	56	56	55	55
00111000	57	57	57	56	56
00111001	58	58	58	57	57

Binary System Code	Default Protocol	PELCO-D	PELCO-P	SAMSUNG	KALATEL
00111010	59	59	59	58	58
00111011	60	60	60	59	59
00111100	61	61	61	60	60
00111101	62	62	62	61	61
00111110	63	63	63	62	62
00111111	64	64	64	63	63
01000000	65	65	65	64	64
01000001	66	66	66	65	65
01000010	67	67	67	66	66
01000011	68	68	68	67	67
01000100	69	69	69	68	68
01000101	70	70	70	69	69
01000110	71	71	71	70	70
01000111	72	72	72	71	71
01001000	73	73	73	72	72
01001001	74	74	74	73	73
01001010	75	75	75	74	74
01001011	76	76	76	75	75
01001100	77	77	77	76	76
01001101	78	78	78	77	77
01001110	79	79	79	78	78
01001111	80	80	80	79	79
01010000	81	81	81	80	80
01010001	82	82	82	81	81
01010010	83	83	83	82	82
01010011	84	84	84	83	83
01010100	85	85	85	84	84
01010101	86	86	86	85	85
01010110	87	87	87	86	86
01010111	88	88	88	87	87

Binary System Code	Default Protocol	PELCO-D	PELCO-P	SAMSUNG	KALATEL
01011000	89	89	89	88	88
01011001	90	90	90	89	89
01011010	91	91	91	90	90
01011011	92	92	92	91	91
01011100	93	93	93	92	92
01011101	94	94	94	93	93
01011110	95	95	95	94	94
01011111	96	96	96	95	95
01100000	97	97	97	96	96
01100001	98	98	98	97	97
01100010	99	99	99	98	98
01100011	100	100	100	99	99
01100100	101	101	101	100	100
01100101	102	102	102	101	101
01100110	103	103	103	102	102
01100111	104	104	104	103	103
01101000	105	105	105	104	104
01101001	106	106	106	105	105
01101010	107	107	107	106	106
01101011	108	108	108	107	107
01101100	109	109	109	108	108
01101101	110	110	110	109	109
01101110	111	111	111	110	110
01101111	112	112	112	111	111
01110000	113	113	113	112	112
01110001	114	114	114	113	113
01110010	115	115	115	114	114
01110011	116	116	116	115	115
01110100	117	117	117	116	116
01110101	118	118	118	117	117

Binary System Code	Default Protocol	PELCO-D	PELCO-P	SAMSUNG	KALATEL
01110110	119	119	119	118	118
01110111	120	120	120	119	119
01111000	121	121	121	120	120
01111001	122	122	122	121	121
01111010	123	123	123	122	122
01111011	124	124	124	123	123
01111100	125	125	125	124	124
01111101	126	126	126	125	125
01111110	127	127	127	126	126
01111111	128	128	128	127	127
10000000	129		129		128
10000001	130		130		129
10000010	131		131		130
10000011	132		132		131
10000100	133		133		132
10000101	134		134		133
10000110	135		135		134
10000111	136		136		135
10001000	137		137		136
10001001	138		138		137
10001010	139		139		138
10001011	140		140		139
10001100	141		141		140
10001101	142		142		141
10001110	143		143		142
10001111	144		144		143
10010000	145		145		144
10010001	146		146		145
10010010	147		147		146
10010011	148		148		147

Binary System Code	Default Protocol	PELCO-D	PELCO-P	SAMSUNG	KALATEL
10010100	149		149		148
10010101	150		150		149
10010110	151		151		150
10010111	152		152		151
10011000	153		153		152
10011001	154		154		153
10011010	155		155		154
10011011	156		156		155
10011100	157		157		156
10011101	158		158		157
10011110	159		159		158
10011111	160		160		159
10100000	161		161		160
10100001	162		162		161
10100010	163		163		162
10100011	164		164		163
10100100	165		165		164
10100101	166		166		165
10100110	167		167		166
10100111	168		168		167
10101000	169		169		168
10101001	170		170		169
10101010	171		171		170
10101011	172		172		171
10101100	173		173		172
10101101	174		174		173
10101110	175		175		174
10101111	176		176		175
10110000	177		177		176
10110001	178		178		177

Binary System Code	Default Protocol	PELCO-D	PELCO-P	SAMSUNG	KALATEL
10110010	179		179		178
10110011	180		180		179
10110100	181		181		180
10110101	182		182		181
10110110	183		183		182
10110111	184		184		183
10111000	185		185		184
10111001	186		186		185
10111010	187		187		186
10111011	188		188		187
10111100	189		189		188
10111101	190		190		189
10111110	191		191		190
10111111	192		192		191
11000000	193		193		192
11000001	194		194		193
11000010	195		195		194
11000011	196		196		195
11000100	197		197		196
11000101	198		198		197
11000110	199		199		198
11000111	200		200		199
11001000	201		201		200
11001001	202		202		201
11001010	203		203		202
11001011	204		204		203
11001100	205		205		204
11001101	206		206		205
11001110	207		207		206
11001111	208		208		207

Binary System Code	Default Protocol	PELCO-D	PELCO-P	SAMSUNG	KALATEL
11010000	209		209		208
11010001	210		210		209
11010010	211		211		210
11010011	212		212		211
11010100	213		213		212
11010101	214		214		213
11010110	215		215		214
11010111	216		216		215
11011000	217		217		216
11011001	218		218		217
11011010	219		219		218
11011011	220		220		219
11011100	221		221		220
11011101	222		222		221
11011110	223		223		222
11011111	224		224		223
11100000	225		225		224
11100001	226		226		225
11100010	227		227		226
11100011	228		228		227
11100100	229		229		228
11100101	230		230		229
11100110	231		231		230
11100111	232		232		231
11101000	233		233		232
11101001	234		234		233
11101010	235		235		234
11101011	236		236		235
11101100	237		237		236
11101101	238		238		237

Binary System Code	Default Protocol	PELCO-D	PELCO-P	SAMSUNG	KALATEL
11101110	239		239		238
11101111	240		240		239
11110000	241		241		240
11110001	242		242		241
11110010	243		243		242
11110011	244		244		243
11110100	245		245		244
11110101	246		246		245
11110110	247		247		246
11110111	248		248		247
11111000	249		249		248
11111001	250		250		249
11111010	251		251		250
11111011	252		252		251
11111100	253		253		252
11111101	254		254		253
11111110	255		255		254
11111111	256		256		255

IX. Exception Handling

Issue	Possible Reason	Solution
Power on, no movement, no image, indicator light does not light	Power line connected wrong	Correct it
	Power damaged	Replace
	Blowout	Replace
	Power line be connected bad	Check it
Power on, self check, has image, can't control, indicator light does not flicker	The machine's address code or baud rate is wrong	Reset
	Protocol wrong	Correct it
	RS485 bus be connected wrong	Check it
Camera can't reposition itself. (Camera can no longer move)	Mechanical failure	Repair it
	Camera incline	Correct it
	Power is not enough	Replace
Image is not stable	Video line connected bad	Check it
	Power is not enough	Replace
Image is dim	Focus in manual state	Operate the machine or adjust a preset position
	Dome is dirty	Clean it
Control is not stable	Power supply is not enough	Change a certified power supply
	The matching resistance of the furthest speed dome is not working	Make the matching resistance work
	Camera can not control resulting from incorrect operation	Reboot the machine